

Digi Connect[®] EM Family

Wired and Wireless Embedded Modules

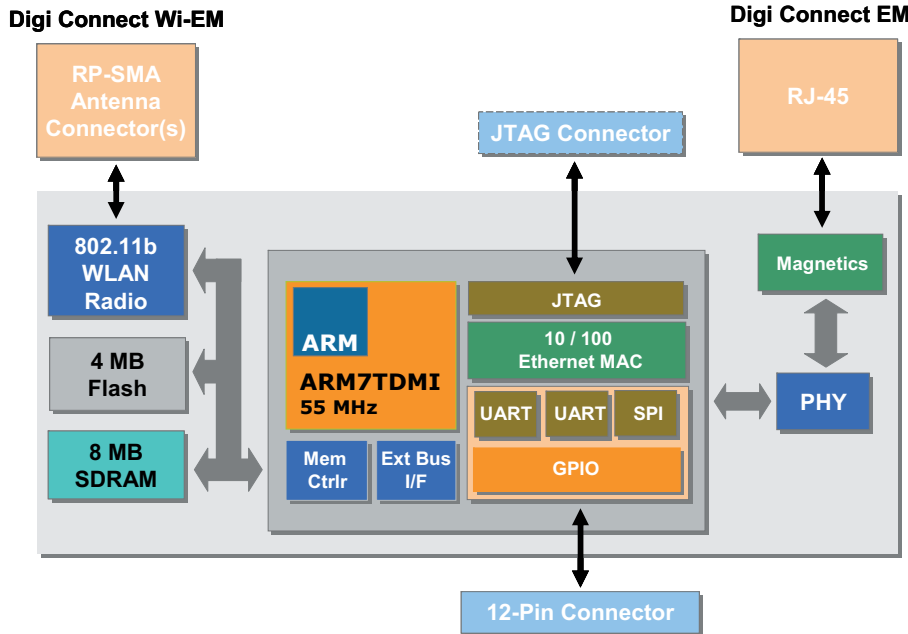

The Digi Connect EM and the Digi Connect Wi-EM are the industry's first interchangeable secure embedded modules, delivering wired and wireless Ethernet network connectivity that is cost-effective and easy to implement.



Features/Benefits

- Highly integrated 32-bit network co-processor module
- Pin-compatible single component solutions
- 4 MB Flash and 8MB RAM on board
- 2 high-speed serial interfaces
- Shared SPI and 9 shared GPIO option
- 10/100 Mbit Ethernet or 802.11b WLAN with WPA2/802.11i
- Fully pre-certified radio reduces overall design cost/risk and time-to-market
- Industrial operating temperature and FCC Class B compliant low-emission design
- NIST-certified 256-bit AES encryption based on SSL/TLS
- ThreadX[®]-based NET+OS(R) software development platform
- Digi plug-and-play firmware option eliminates software development effort
- Digi's own ARM processor and WLAN technology for true long-term product availability
- Seamless migration path to Digi NET+ARM system-on-chip

Overview

Wireless technology creates a new dimension in a rapidly emerging world of ubiquitous networking collaboration in which billions of networked electronic devices work invisibly and jointly with each other and with people. Making the right network technology decisions is a key factor for market success and the competitive edge of your products.

The Digi Connect EM product family delivers a flexible and reliable set of network connectivity solutions. This powerful product offering is cost-effective and easy to implement, ensuring that Original Equipment Manufacturers (OEMs) will keep pace with evolving network technologies.

Based on a common platform design approach, the Digi Connect EM and Digi Connect Wi-EM embedded modules offer complete "drop-in" integration combined with true long-term product availability. This allows you to build future-proof products on a single layout design by simply selecting between 10/100 wired and secure (WPA2) wireless by a population option.

The Digi Connect EM family makes this possible without the traditional complexities of hardware and software integration work, and at a fraction of the time and cost required to create your own custom solutions.

The modules feature a variety of connectivity options, such as two high-speed serial ports, an SPI master mode interface available to NET+OS applications, and nine shared GPIOs. For additional integration flexibility, they are available in two low-profile population options, with or without onboard LED array and an Ethernet connector. Additional customer-specific population options are available on request.

Built on leading Digi 32-bit NET+ARM processor technology, the Digi Connect EM family of embedded modules offers serial-to-Ethernet functionality through Digi's plug-and-play firmware, and the freedom and flexibility of professional embedded software development provided by the easy-to-use, cost-effective, and complete Digi JumpStart Kits for NET+OS.



DIGI PLUG-AND-PLAY INTEGRATION KIT: OVERVIEW

Digi Integration Kits provide everything needed for evaluation, rapid prototyping and integration of Digi Connect embedded modules using the feature-rich and field-proven Digi plug-and-play firmware.

The Digi plug-and-play firmware in combination with the design of the Digi Connect EM and Digi Connect Wi-EM modules dramatically reduces time-to-market by eliminating time-consuming embedded hardware and software development. They deliver instant and fully transparent wired and wireless device server networking functionality for all existing and new product designs, and allow you to quickly network enable your products while focusing on your core product design competency.

Digi plug-and-play firmware offers industry-leading features such as a robust TCP/IP stack with support for IPv4 and IPv6, universal IP address assignment, integrated web server (HTTP/HTTPS), web user interface with private labeling/branding options, user management, custom Java applet support, user file system, NIST-certified 256-bit AES encryption (plus DES and 3DES), SSL/TLS, SSH, Modbus, intelligent device management via SNMP, email alarms, XML-based configuration options, and Digi's patented RealPort® COM/TTY port redirection. These features make it an ideal solution for every network-enabled application that requires ready-made versatility and performance.

- **Complete kit for product evaluation, rapid prototyping, and integration**
- **Transparent wired and wireless serial device server functionality**
- **Digi plug-and-play firmware eliminates embedded software development effort**
- **Strong, standards-based wired and wireless security out-of-the-box**
- **Full private-labeling/branding supported out-of-the-box**

DIGI JUMPSTART KIT FOR NET+OS 7.X : OVERVIEW

The easy-to-use, cost-effective, and complete Digi JumpStart Kit for NET+OS delivers a royalty-free turnkey solution for embedded software development based on the ThreadX Real-Time Operating system (RTOS).

With over 400 million deployments in products worldwide, ThreadX is one of the most reliable and field-proven RTOS solutions available. In addition to ThreadX, NET+OS provides the integrated building blocks needed to create secure and fully network-enabled product solutions using Digi embedded modules and microprocessors. This includes a dual-mode IPv4/IPv6 TCP/IP stack, integrated web server, SNMPv3, POP/SMTP mail, PPP, XML, LDAP, SSL/TLS, and support for enterprise-grade WPA2/802.11i wireless LAN security.

The Digi JumpStart Kit for NET+OS minimizes product design risks and dramatically shortens traditional time-to-market aspects of your C-based embedded product development by providing all needed software and hardware components right out of the box.

Digi ESP for NET+OS, the Microsoft Windows-based Integrated Development Environment (included), offers an easy-to-use Eclipse-based graphical interface with editor, single-step debugging, managed make files, build environment, online help, and innovative features like the Digi project builder wizard. Through simple point-and-click operation it generates a completely functional, customized application framework with ready-to-use software components such as web-based network interface configuration, FTP-based firmware upgrade, SSL/TLS, serial and Telnet Command Line Interface (CLI), and more.



- **Royalty-free turnkey solution for embedded software development**
- **Built on field-proven and compact ThreadX Real-Time Operating System**
- **Fully integrated, standards-based secure wired and wireless networking**
- **Professional state-of-the-art software development using Digi ESP or optional Green Hills MULTI* development tools**
- **Seamless migration to other Digi NET+ARM module platforms and fully integrated system-on-chip solutions**

*Requires purchase of third party product. See website for additional information.

DIGI PLUG-AND-PLAY INTEGRATION KIT: CONTENTS

- Digi Connect EM or Digi Connect Wi-EM module
 - 4 MB Flash, 8 MB SDRAM, 2 dBi dipole antenna (Digi Connect Wi-EM)
- Development board
 - 2 RS-232 serial ports, GPIO configuration/test switches (hi/lo), screw terminal for GPIO signals, status LEDs (serial, GPIO, power), logic signal header, test points, reset button, 9-30VDC power supply w/Power-over-Ethernet support (mid-span), SPI header, JTAG header (JTAG modules)
- Digi Connect Integration Kit CD
 - Device discovery tool w/source code, device configuration wizard w/source code, RCI library, device discovery (ADDP) library, Java applet sample source code, C/C++ sample source code (TCP, UDP, SSL)
- Documentation
 - Getting started, hardware reference manual, development board schematics Digi Connect user's guide, command line reference, RCI specification
- Power supply and accessories
 - External wall power supply (110/240VAC to 12VDC @ 850 mA) with interchangeable outlet adapters (North America, EU, UK, and Australia), JTAG adapter, crossover serial cable, Ethernet cable (Digi Connect EM)

NET+OS 7.X JUMPSTART KIT: CONTENTS

- Digi Connect EM or Digi Connect Wi-EM module
 - 4 MB Flash, 8 MB SDRAM, 2 dBi dipole antenna (Digi Connect Wi-EM)
- Development board
 - 2 RS-232 serial ports, GPIO configuration/test switches (hi/lo), screw terminal for GPIO signals, status LEDs (serial, GPIO, power), logic signal header, test points, reset button, 9-30VDC power supply w/Power-over-Ethernet support (mid-span), SPI header, JTAG header (JTAG modules)
- Digi JTAG link USB 2.0 hardware debugger
- Digi NET+OS CD
 - NET+OS 7.x, Digi ESP IDE, BSP source code, sample code, Green Hills MULTI* IDE support, documentation
- Documentation
 - Quick start guide, Digi ESP tutorial, NET+OS porting guide, NET+OS API documentation, Advanced Web Server, hardware reference manual, development board schematics
- Power supply and accessories
 - External wall power supply (110/240VAC to 12VDC @ 850 mA) with interchangeable outlet adapters (North America, EU, UK, and Australia), JTAG adapter, crossover serial cable, Ethernet cable (Digi Connect EM)



*Requires purchase of third party product. See website for additional information.

Features/Specifications

HARDWARE

- 32-bit Digi NET+ARM high-performance RISC processor - NS7520 @ 55 MHz
- 4 MB Flash and 8 MB RAM
- On-board power supervisor
- 2 high-speed TTL serial interfaces
 - Throughput up to 230 Kbps
 - TXD, RXD, RTS, CTS, DTR, DSR, and DCD on Port 1
 - TXD, RXD on Port 2
 - Hardware/Software flow control
- Serial Peripheral Interface (SPI)
 - Master mode only
- 9 shared GPIO ports

NETWORK INTERFACE

Wired

- Standard: IEEE 802.3
- Physical layer: 10/100Base-T
- Data rate: 10/100 Mbps (auto-sensing)
- Mode: Full or half duplex (auto-sensing)
- Connector: RJ-45

Wireless LAN

- Standard: IEEE 802.11b
- Frequency: 2.4 GHz
- Data rate: Up to 11 Mbps w/fallback
- Modulation: DBPSK (1 Mbps), DQPSK (2 Mbps), CCK (11,5.5 Mbps),
- Transmit power: 16 dBm typical
- Receive sensitivity: -82 dBm @ 11 Mbps
- Connector: 1/2 x RP-SMA

WLAN SECURITY

- WEP (Wired Equivalent Privacy)
 - 64/128-bit encryption (RC4)
- WPA/WPA2/802.11i
 - 128-bit TKIP/CCMP (AES) encryption
 - Enterprise mode (802.1X)
 - LEAP (WEP only), PEAP, TTLS, TLS
 - GTC, MD5, OTP, PAP, CHAP, MSCHAP, MSCHAPv2, TTLS-MSCHAPv2

ENVIRONMENTAL

Digi Connect EM

- Operating temperature: -40° C to 85° C (-40° F to 185° F)
- Storage temperature: -50° C to 125° C (-58° F to 257° F)
- Relative humidity: 5% to 90% (non-condensing)
- Altitude: 12,000 feet (3,658 meters)

Digi Connect Wi-EM

- Operating temperature: -30° C to 85° C (-22° F to 185° F)
- Storage temperature: -50° C to 125° C (-58° F to 257° F)
- Relative humidity: 5% to 90% (non-condensing)
- Altitude: 12,000 feet (3,658 meters)

POWER REQUIREMENTS

Digi Connect EM

- 3.3VDC @ 270 mA max (891 mW)

Digi Connect Wi-EM

- 3.3VDC @ 400 mA max (1.32 W)

REGULATORY APPROVALS

- FCC Part 15 Class B, EN 55022 Class B
- EN 61000-3-2 and EN 61000-3-3
- ICES-003 Class B, VCCI Class II, AS 3548
- FCC Part 15 Sub C Section 15.247
- IC RSS-210 Issue 5 Section 6.2.2(o)
- EN 300 328, EN 301 489-17
- UL 60950-1, EN 60950 (EU)
- CSA C22.2, No. 60950
- EN 55024

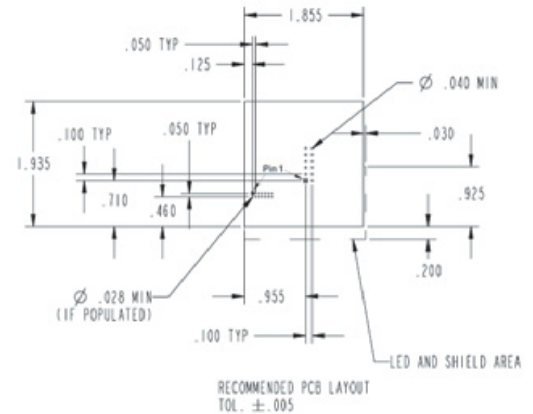

DIMENSIONS

Digi Connect EM

- Length: 1.935" (49.149 mm)
- Width: 1.575" (40.005 mm)
- Height: 0.670" (17.018 mm)

Digi Connect Wi-EM

- Length: 1.935" (49.149 mm)
- Width: 1.855" (47.117 mm)
- Height: 0.0653" (16.586 mm)

Height and width (overhang) varies depending on connector population. See hardware reference manual for additional information.

MODEL.....PART NUMBERS

Model

Digi Connect EM Family Integration Kit
Digi Connect EM Family Digi JumpStart Kit for NET+OS

Digi Connect EM

Kit DC-EM-KT
DC-EM-NET

Digi Connect Wi-EM

DC-WEM-KT
DC-WEM-NET

See Digi website for complete list of available part numbers and accessories.



DIGI SERVICE AND SUPPORT - You can purchase with confidence knowing that Digi is here to support you with expert technical support and a strong five-year warranty. www.digi.com/support

WHEN
RELIABILITY
MATTERS™

Digi International

11001 Bren Road E.
Minnetonka, MN 55343
U.S.A.
PH: 877-912-3444
952-912-3444
FX: 952-912-4952
email: info@digi.com

Digi International

France
31 rue des Poissonniers
92200 Neuilly sur Seine
PH: +33-1-55-61-98-98
FX: +33-1-55-61-98-99
www.digi.fr

Digi International

KK
NES Building South 8F
22-14 Sakuragaoka-cho,
Shibuya-ku
Tokyo 150-0031, Japan
PH: +81-3-5428-0261
FX: +81-3-5428-0262
www.digi-intl.co.jp

Digi International

(HK) Limited
Suite 1703-05, 17/F.,
K Wah Centre
191 Java Road
North Point, Hong Kong
PH: +852-2833-1008
FX: +852-2572-9989
www.digi.cn

Digi International, the leader in device networking for business, develops reliable products and technologies to connect and securely manage local or remote electronic devices over the network or via the web. With over 20 million ports shipped worldwide since 1985, Digi offers the highest levels of performance, flexibility and quality.

www.digiembedded.com

© 2004-2008 Digi International Inc.

Digi, Digi International, the Digi logo, the When Reliability Matters logo, Digi Connect, Digi Connect, Digi JumpStart Kit, NET+ and NET+OS are trademarks or registered trademarks of Digi International Inc. in the United States and other countries worldwide. ARM and NET+ARM are trademarks or registered trademarks of ARM Limited. All other trademarks are the property of their respective owners.

91001257
C2/308

